

Elevator Cab Interior Maintenance & Inspection Checklist

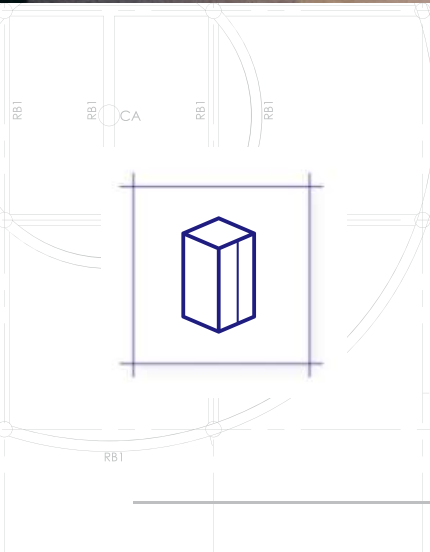

WALLS

- Check for any signs of damage on the wall panels, mirrors, handrails and toe kicks.
- Keep elevator cab noticeboards up to date and remove old signs or notices.
- Use wall protection pads when moving any equipment, furniture, or other large or bulky items.
- Clean mirrors using a glass cleaner and a lint-free, soft rag or microfibre towel.

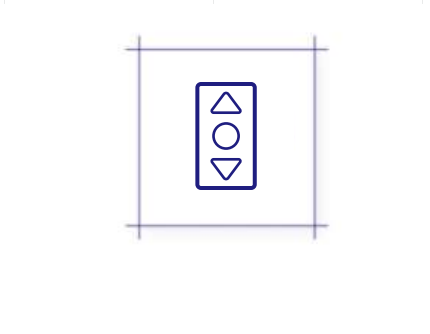

BUTTONS

- Inspect car control panel for any stuck buttons.
- Troubleshoot jammed buttons and remove dirt around the edges.
- Check control panel lights and floor indicator to make sure they're all working properly.

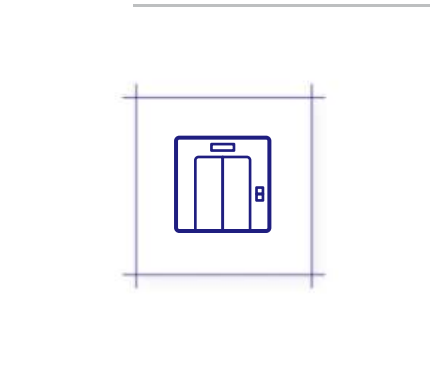

DOORS

- Confirm that the doors are opening and closing smoothly without any obstruction, slamming or bouncing.
- Check for dents, scratches and other signs of damage with door cladding.

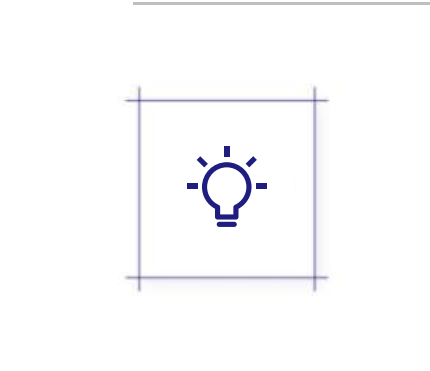

CEILING + LIGHTS

- Check if there are any burned-out lights and replace them.
- Inspect the ceiling for damaged, misaligned or loose panels.
- Make sure ceiling panels are sound-proof and friction-proof from the machinery above.

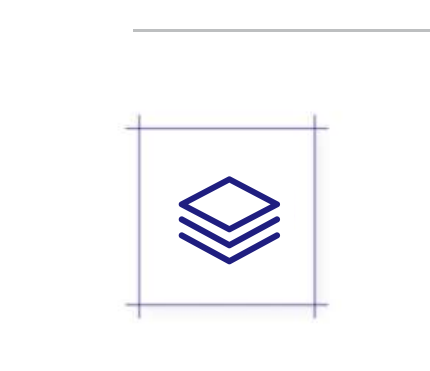

FLOORS

- Check with your local codes to be sure that your elevator floor will not create a tripping hazard.
- Sweep and mop floors regularly to remove debris or spilled liquids.
- Polish or vacuum elevator cab flooring to keep it clean and dirt-free.

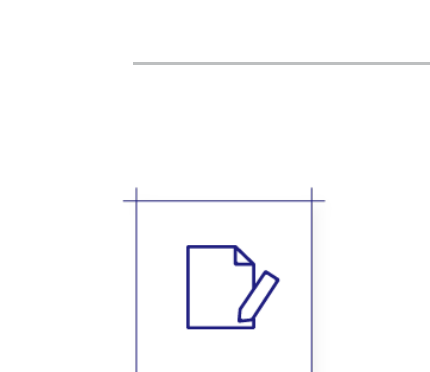

OTHER

- Use a non-toxic, non-aerosol, pH-neutral, bleach-free and ammonia-free cleaner for disinfecting and polishing your elevator surfaces.
- Never spray any substance directly on the button or panel surfaces.
- Ensure that the emergency phone connects will the local fire department quickly.
- Confirm that the smoke detector and fire alarm system are working properly.
- Keep quality records to log the use and condition of your elevator cab interiors.

