

# SLING SURVEY FORM

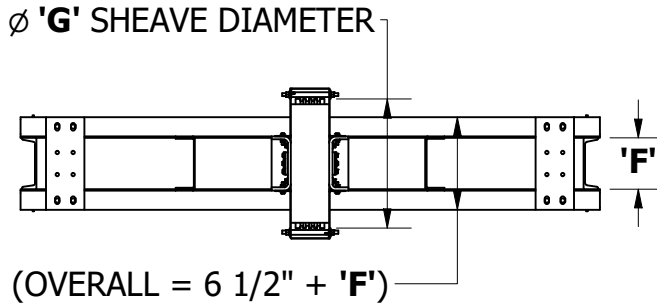

EQUIPMENT / SPECIFICATIONS	
ROLLER GUIDES	
SAFETY	
BUFFER QTY/TYPE	
ROPE QTY/SIZE	
STILE CHANNEL	

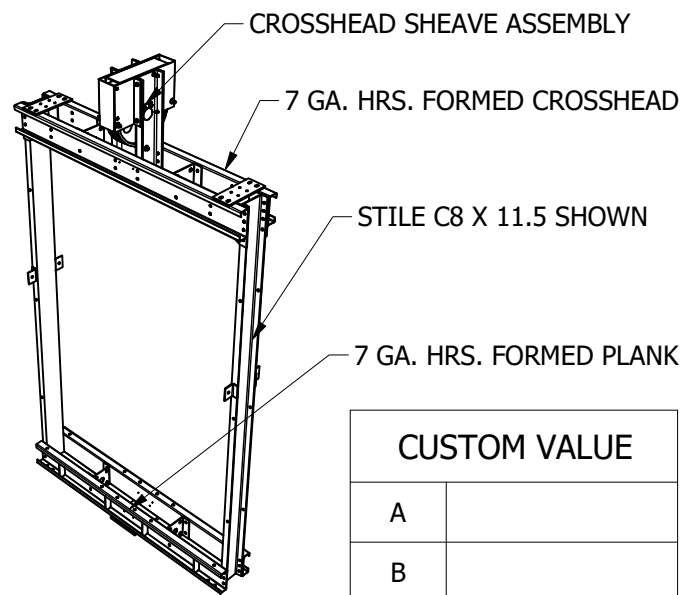
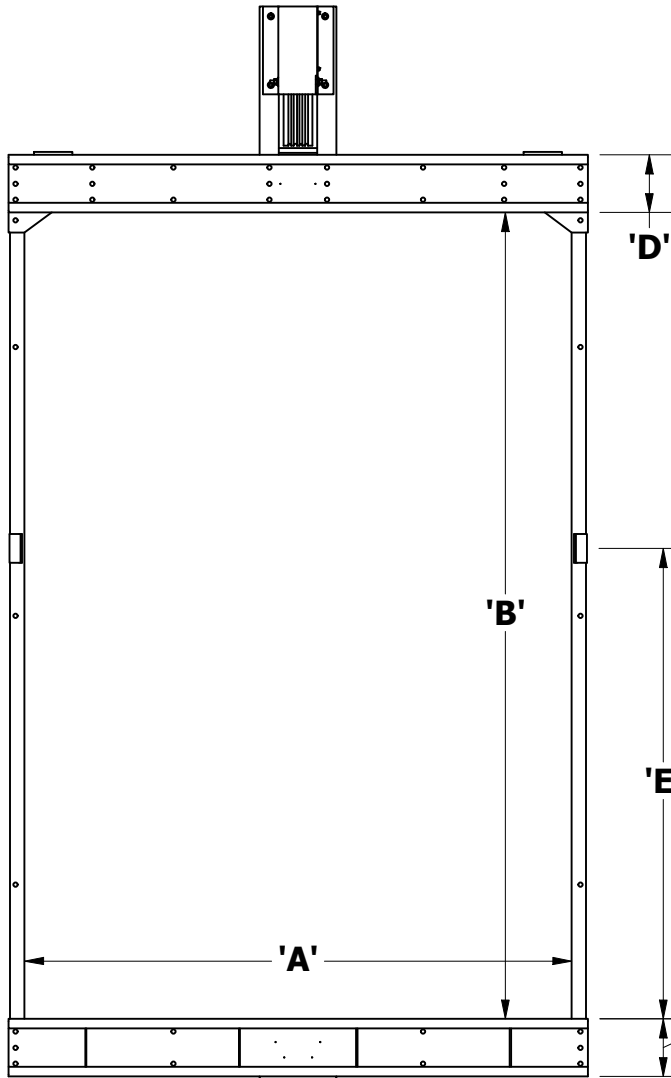

CUSTOM VALUE	
A	
B	
C	
D	
E	
F	
G	

ORDER INFORMATION	
COMPANY NAME	
P.O.#	
JOB NAME	

## FORMED SLING 2:1 ROPING

THIS DRAWING IS THE PROPERTY OF AVT-BECKETT ELEVATOR LTD., AND IS LOANED UNDER THE EXPRESS CONDITIONS THAT IT MUST NOT BE COPIED OR USED WITHOUT PERMISSION AND IS TO BE RETURNED ON DEMAND.



AVT Beckett Elevators  
www.avtbeckett.com